

Metal fused METACLAMP® sight-glasses for NA-Connect™-connections



NA-Connect™ sightglass

Application:

For NA-Connect™-connections with connection sizes to DIN 32 676 / ISO 2852

Advantages:

- Extremely compact construction
- High security
- Easy installation
- For sterile applications
- CIP cleaning possible

Technical data of METACLAMP® sightglasses:

- Test base: DGRL 97 / 23 / EG, AD 2000 standards, DIN 7079-1 May 1999
- Materials to VdTÜV specifications and the respective DIN/EN standards
- Glass quality: Borosilicate glass to DIN 7080

Certificates:

To be supplied to DIN EN 10204-3.1 against extra charge

Operating conditions:

Temperatures:

Ring materials:	1.4462:	-30 °C to +280 °C
	2.4602:	-60 °C to +300 °C
	2.4610:	-60 °C to +300 °C

Technical data of NA-Connect™ system:

- Materials welding flange: 316 L / 1.4435
 - Materials holding ring: 316 L / 1.4404
 - Nominal pressure: 7 bar (PN 7)
 - Nominal temperature: 150 °C
- } Not contained in our delivery

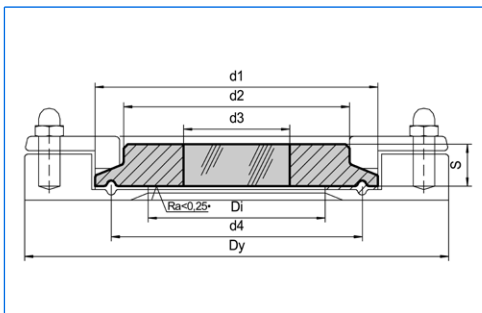

Typical assembly

Homologations:

ASME BPE 2005

Dimensions:

Nominal diameter		PN	d1	d2	d3	d4	S	Dy	Di
DIN	Tube OD								
NAC-DIN-20	-	16	34,0	18,0	10	27,5	7	70	20,0
NAC-DIN-40	(NAC-OD-1 ½")	16	50,5	38,0	25	43,5	10	85	35,5
NAC-DIN-50	(NAC-OD-2")	16	64,0	51,0	30	56,5	10	100	48,5
-	(NAC-OD-2 ½")	16	77,5	63,5	35	70,5	10	112	60,2
NAC-DIN-65	(NAC-OD-3")	10	91,0	76,0	40	83,5	10	131	72,0
NAC-DIN-80	-	10	106,0	88,9	50	97,0	10	146	84,9
NAC-DIN-100	(NAC-OD-4")	10	119,0	101,0	55	110,0	12	170	97,6

Branch office / exclusive agent:

All dimensions in mm. Subject to changes without preliminary notice.